

**Winston Speedway**  
**2017**  
**Mini Wedge Rules (MWA Rules)**

*Rules may be changed / amended by MWA, when deemed necessary.*

**Mini Wedge Association Mission:**

To provide the safest racing program possible designed to teach young drivers 6-14 years of age the skill, sportsmanship and fair play needed to compete on and off the race track.

**Vision:**

MWA will be a great experience for both parent and child. Opportunities for continuous education and growth will foster personal and career growth. Our efforts will be recognized by others who view us as a benchmark for safety and fairness.

**Values:**

We must strive to provide a fun and safe environment for every person. We do believe all of our members desire to excel in their life. We must treat each other fairly with respect, plus offer encouragement and appreciation as we work together towards the same goals. To promote families spending good quality time together, at or away from the racetrack.

**2017 Rules and Regulations:**

Car – Section 1

Engine – Section 2

Race Rules – Section 3

Driver Personal Safety – Section 4

Body Drawings / Specs – Section 5

Point System – Section 6

Race Procedure – Section 7

The MWA encourages a fun, family atmosphere. Times may arise that are stressful and upsetting to both parents and the driver. When addressing these issues, please speak in a manner that is respectful not only to the driver, but to others that are within hearing distance.

The following are rules for the Mini Wedge Association. Membership in the MWA shall be \$25.00 per year. Membership is also required at all the MWA tracks. Membership applications can be obtained by contacting Anji Morey at (740) 837-1804 or request your copy by email at [anmorey@gmail.com](mailto:anmorey@gmail.com).

**Section 1 – Car**

1. Wheelbase 45” - 49”. Maximum width of the outside of the tire is 49”. There are to be no roofs or sail panels. A maximum of a 3 inch spoiler will be allowed. Spoiler side's maximum height will be 3 inches from deck and 5 inches long.
2. All karts must be constructed of steel tubing with a complete 6-point roll cage including adequate side protection. Cages must be a minimum of .065 x 1” steel tubing welded to the frame.
3. The engine must be located behind the driver's seat. No part of the engine can be located beside the seat.
4. Floor pans are required to be made of steel or minimum .040” aluminum. The floor pans are to be securely bolted or riveted to the frame. The length of the floor pan must

- go from the center of the seat to the front of the frame going past the driver's pedals.
5. All karts must have a fully wedge Late Model appearing body. No open fenders will be allowed. There must be at least 4" of body behind the rear wheels. There will be no covered or enclosed motors all motors will remain completely visible at all times. See body drawings for more information.
  6. Tires must be a Hoosier (15600 "11 inches tall" or 15500 "10-1/2 inch tall"). No grooving or sipping of the tires. No treating or soaking of tires. Tires must durometer 50, any tire that durometer is 48 or less will be deemed as treated and will result in a 12 month suspension.
  7. Rim width cannot be any wider than 6-1/2" wide and must be at least 6" tall.
  8. Axle must be a steel axle and a minimum of 3/16" wall thickness.
  9. No suspension will be allowed. This includes springs, shocks, rubbers, torsion bars and any other type of dampening device.
  10. Rear deck height cannot exceed a maximum of 24" from the ground and a minimum of 20" high from the ground.
  11. Body must be constructed of .040" aluminum. Plastic may be used for nose, fenders and trim.
  12. Kart must weigh no less 335 lbs. With driver after the race. When tracks split the class by age they must split it by 6-9 and 10-14 years old. The 10-14 year old kids must weigh in no less than 375 lbs with driver after the race. (MWA tracks can chose to weigh in before or after the race.)
  13. We highly encourage the doors and quarter panels to be wider than the track with at the bottom of the doors and quarters to help prevent "wheel hop".
  14. At least one vertical door bar must be welded on each side of the driver running from the main rail to side crash bars for driver protection. See rear side view drawing for more details.
  15. Front and rear bumpers must be mounted at all times. Front and rear bumpers must have at least a 6" tall hoop.
  16. Front and rear down tubes are mandatory for driver's protection.
  17. All tubing on main roll cage must be at least .065" wall tubing.
  18. Driver's seat must be mounted in four locations (4-bolts).
  19. Two door numbers must be present with a minimum of 12".
  20. Must at all times have two return springs.
  21. Kill switch must be mounted on the deck visible to officials.
  22. Any weight mounted on the kart must be painted white with the drivers name and number on the weight. Weight must be mounted by at least a 1/2" bolt. Any weight lost during an event will result of a two week suspension.
  23. 5-point harness system is mandatory. All harness must have a SFI rated patch.
  24. All karts must have two triangle type side window nets attached to the roll bar one on each side of the driver.
  25. If you run the Butlerbilt full containment seat you are not required to run a window net.

## **Section 2 – Engine**

1. Two engines will be allowed in 2017 both using a MWA spec restrictor plate. Restrictor plate must be purchased from MWA and serial number must stay with that driver.
2. 6.5 HP (212cc) OHV Predator Engine will be allowed until the end of 2017 season. MWA Spec Honda 6.5 HP engine will become the Spec engine starting in 2018. The engine will come sealed with serial numbered tag. If the tags are removed or altered in any way it will result of a 12 month suspension. MWA Spec Honda engines will be

available through MWA.

3. Engine must remain stock.
  - A. You can disconnect the governor.
  - B. You cannot alter the exhaust in any way.
  - C. You can change the spark plug.
  - D. You can disconnect the low oil sensor.
  - E. You can run an ARC Air Cleaner.
  - F. You can change jets.
4. Noram "Magnum" Premier clutch is allowed in 2017. This clutch can ONLY be purchased from MWA and must have serial number.
5. Tomar 2-Disc clutch is allowed in 2017. This clutch is a spec clutch and can only be purchased from MWA. This clutch has a spec spring, this spring is the only spring allowed in competition. You can send a Tomar 2-Disc clutch to MWA to be converted over. At any time an MWA official or track official can remove your spring to check wire thickness.
6. MAX-Torque clutch is allowed in 2017.
7. Starting in 2017 you can run 12, 13 or 14 tooth clutches. (This is to help decrease our rear axle gear for more ground clearance.)
8. Engine claim is set to \$100, anyone finishing the feature can claim any driver at any time that is running a Harbor FRT engine. An MWA official can also swap a motor at any time for a brand new engine. This claim is the engine only, that does not include the carburetor, clutch, chain guard or air cleaner.
9. The mission is to provide children a safe and competitive series to teach them the fundamentals, sportsmanship and completeness needed to grow into the sport as a young adult. Please keep in mind the engine/clutch claim is to give every child the opportunity to compete without the worry of their family not being able to afford it or their family doesn't "cheat" enough to be competitive.

### **Section 3 – Race Rules**

1. All drivers must be accompanied by a parent or legal guardian. Unless you are appointed his/her legal guardian, by law, you cannot sign a release form for them. Therefore they cannot race. Any exception to this rule cannot be made by an MWA official and must be brought before the track's management or track's insurance carrier for a decision.
2. All cars will be lined up according to their pill draw. Failure to draw a pill before the lineup is turned into track officials. This will result in the driver starting at the tail of the heat.
3. Arguing about scoring or judgment calls will not be tolerated. Confrontations/arguments with MWA officials, track officials or another parent can result in a minimal suspension of 2 weeks from all MWA sanctioned tracks.
4. The scoring tower is off limits to drivers and anyone who is not a track staff member.
5. Any parent, driver or member of any team involved in any type of confrontation with anyone at the track will result in a suspension of driver and parent or legal guardian for at least 2 weeks from all MWA events.
6. Age limit is 6-14 years of age. You must provide a copy of your birth certificate before you membership can be provided.
7. There will be NO WARNINGS given out for bad behavior such as; No throwing a fit on the racetrack or pit area, NO jumping on the track officials, MWA officials, scorers, flagman or track owner. No going to another pit to argue this includes driver, crew and

anyone with a Mini Wedge.

#### Section 4 – Driver Personal Safety

1. All drivers must wear an approved SFI – 1 certified or SFI13 – 2A/1 fire suit. SFI certification patch shall be required on fire suit.
2. A full face helmet will be mandatory at all tracks and all MWA events.
3. All drivers must wear a neck brace.
4. All drivers must wear arm restraints.
5. All drivers must wear a closed toe shoe.
6. Fireproof gloves are mandatory at all MWA events.

#### Section 5 – Body Drawing and Specs

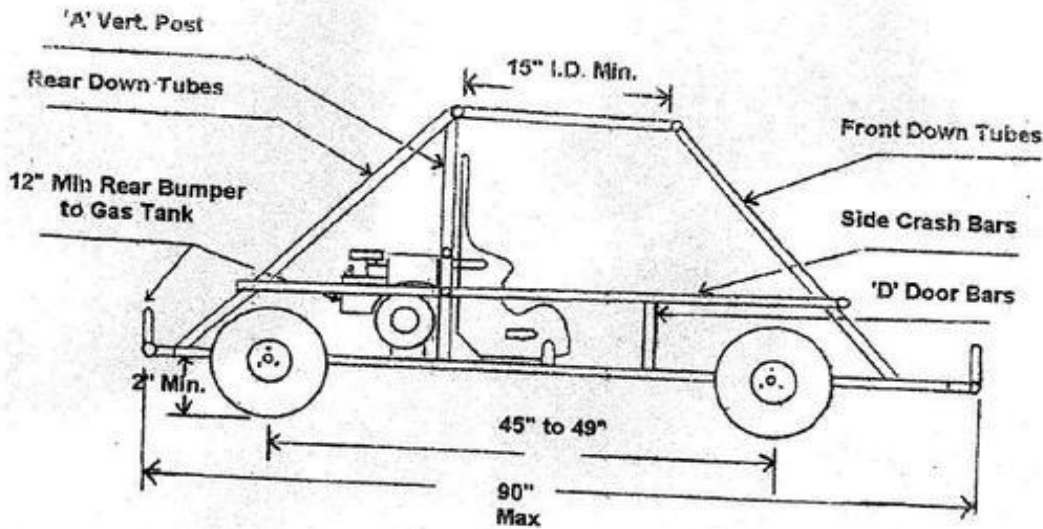

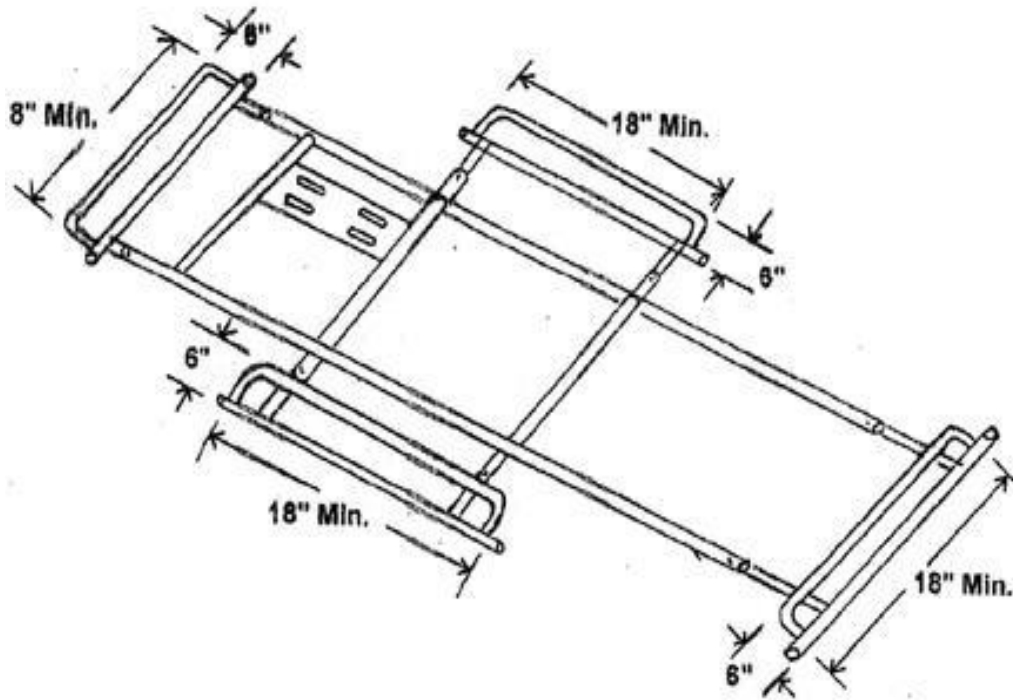

Body Width = 39" - 45" Max  
 Ground Clearance = 2" Min  
 Nose Clearance = 3" Min  
 Tire Clearance = 2" Min

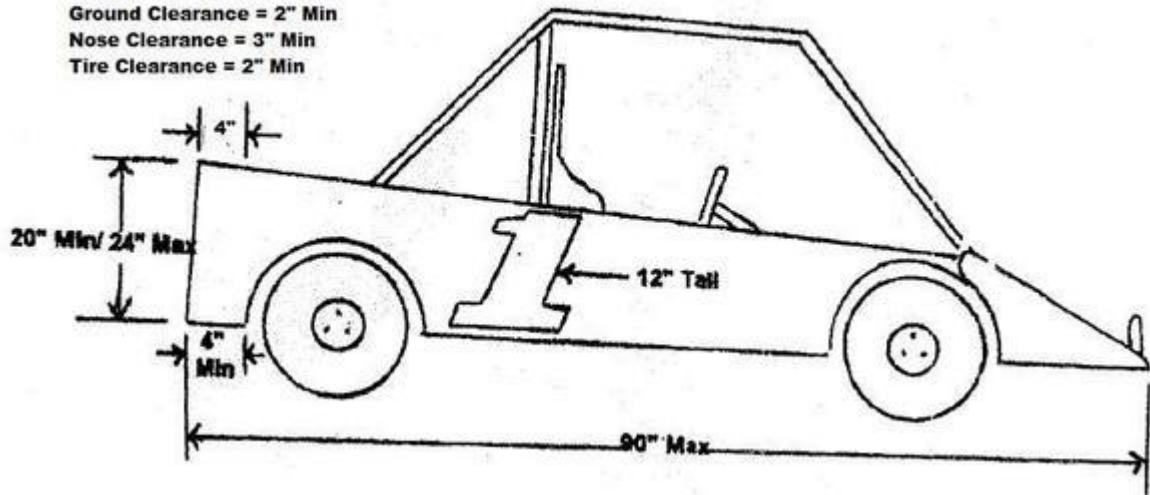

### Section 6 – MWA Point System

1. Drivers not in A Main feature will receive 10 points.
2. 2017 point season begins on May 5, 2017.
3. Top 30 in points will receive awards at year end.

4. Points will be counted for 6-9 year old drivers and also for 10-14 year old drivers. Meaning we will have a champion in both age groups regardless if the tracks are able to split the class. The highest finishing 6-9 year old will be scored 75 points and the highest finishing 10-14 year old will also be scored 75 points.
5. Only a driver's highest points race will be counted each week for events.
6. For any event to award points, a sanction agreement must be in place. Added events must be approved 10 days prior to the event.
7. The driver may begin replacing event points after the driver completes the minimum number of races.
8. Points may be replaced after maximum number of events have been completed, lowest event points race will be replace.
9. Maximum of 12 weeks will be allowed.
10. Drivers must be a member of the MWA to be eligible.
11. All ties will be broken by using the greatest number of 1<sup>st</sup> place finishes during the season. If a tie still exists, the number of 2<sup>nd</sup>. 3<sup>Rd</sup>, etc. will be used in the same manner, until the tie is broken.

### **Section 7 – Race Procedure**

1. Cautions will be thrown when a driver spins out and is stopped on the track.
2. Caution will be thrown when a driver drives off the track and is stuck.
3. The caution car (judgment call) will be put to the tail.
4. Two cautions and the driver will be black flagged for that event.
5. The black flag will be thrown when a driver is driving rough, this is a judgment call and cannot be argued.
6. The class will be split into two classes when the car count allows. 6-9 year olds and 10-14 year olds.
7. Race transponders will be mandatory.
8. Heat races will be decided on by a pill draw.
9. Feature redraw will be set by track.
10. Top 3 will receive a trophy at the end of the night.
11. Top 3 must report to the tech area.